



DUAL POWER AMPLIFIER SJ2822M

GENERAL DESCRIPTION

The SJ2822M is a monolithic integrated circuit in 8 lead Minidip package. It is intended for use as dual audio power amplifier in portable cassette tape players and radios.

● FEATURES

- Dual Low-voltage power amplifier
- Supply voltage down to 1.8V
- Low crossover distortion
- Low quiescent current
- Bridge or stereo configuration

BLOCK DIAGRAM

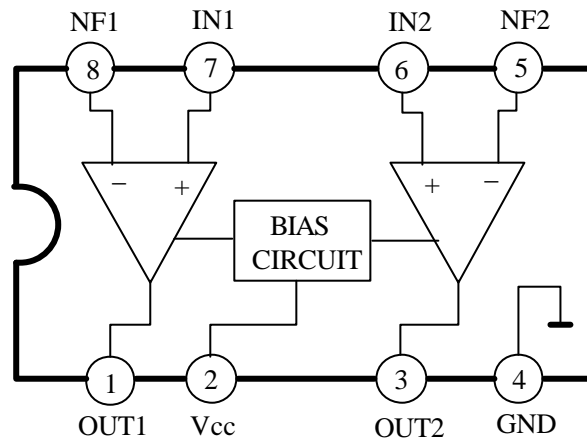

PINNING

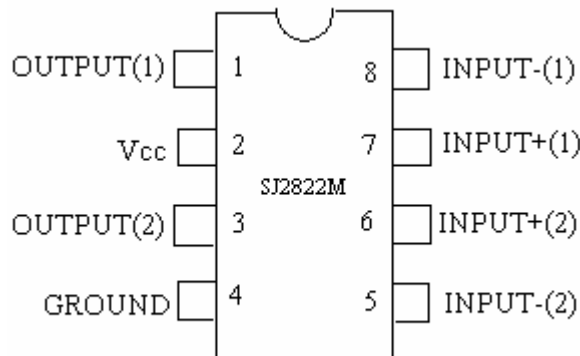

URL: <http://www.szsanjing.com>

----- TEL: 0755-29663136

FAX: 0755-29663137-----



MAXIMUM RATINGS

Characteristics	Symbol	Value	Unit
Supply Voltage	V _{cc}	15	V
Output Peak Current	I _{pk}	1	A
Total Power Dissipation(at T _{amb} =50°C)	P _D	1	W
Total Power Dissipation(at T _{case} =50°C)	P _D	1.4	W
Operating Ambient Temperature Range	T _a	-20~70	°C
Storage Temperature Range	T _{stg}	-40~150	°C

ELECTRICAL CHARACTERISTICS

1.Stereo Test Circuit(Unless otherwise specified V_{cc}=6V,T_{amb}=25°C)

Characteristic	Symbol	Test Condition	Min.	Typ.	Max.	Unit	
Supply Voltage	V _{cc}		1.8		12	V	
Quiescent Output Voltage	V _o			2.7		V	
		V _{cc} =3V		1.2		V	
Quiescent Drain Current	I _d			6	9	mA	
Input Bias Current	I _{BA}			100		nA	
Output Power (Each Channel)	P _o	d=10% f=1kHz V _{cc} =3V R _L =4 V _{cc} =3V R _L =32		110 20		mW	
		d=10% f=1kHz V _{cc} =9V R _L =8 V _{cc} =6V R _L =4 V _{cc} =4.5V R _L =4	0.4	1 0.65 0.32		W	
Distortion	THD	P _o =0.5W R _L =8 f=1kHz V _{cc} =9V		0.3		%	
Closed Loop Voltage Gain	A _{vf}	f=1kHz		40		dB	
Channel Balance	ΔA _{vf}				± 1	dB	
Input Resistance	R _i	f=1kHz	100			k	
Total Input Noise	V _{NI}	R _s =10k B=Cure A		2		μV	
		R _s =10k B=22Hz to22kHz		3			
Supply Voltage rejection	SVR	f=100Hz C1=C2=100 μ F	24	30		dB	
Channel Separation	CSR	f=1kHz		50		dB	

URL: <http://www.szsanjing.com>

----- **TEL: 0755-29663136**

FAX: 0755-29663137 -----



2.Bridge Test Circuit (Unless otherwise specified $V_{cc}=6V, T_{amb}=25^{\circ}C$)

Characteristic	Sym- bol	Test Condition	Min.	Typ.	Max.	Unit
Supply Voltage	V_{cc}		1.8		12	V
Quiescent Drain Current	I_d	$R_L=\infty$		6	9	mA
Output Offset Voltage (Between the Outputs)	V_{os}	$R_L=8$			± 50	mV
Input Bias Current	I_b			100		nA
Output Power	P_o	$d=10\% \quad f=1kHz$ $V_{cc}=9V \quad R_L=16$ $V_{cc}=6V \quad R_L=8$ $V_{cc}=4.5V \quad R_L=8$ $V_{cc}=4.5V \quad R_L=4$		2 1.35 0.7 1		W
		$V_{cc}=3V \quad R_L=4$ $V_{cc}=2V \quad R_L=4$	200	350 80		mW
Distortion	THD	$P_o=0.5W \quad R_L=8 \quad f=1kHz$		0.2		%
Closed Loop Voltage Gain	A_{vf}	$f=1kHz$		40		dB
Input Resistance	R_i	$f=1kHz$	100			k
Total Input Noise	V_{NI}	$R_s=10k \quad \text{Curve A}$		2.5		μV
		$R_s=10k \quad B=22Hz \text{ to } 22kHz$		3		
Supply Voltage Rejection	SVR	$f=100Hz$		40		dB
Power Bandwidth (-3dB)	B	$R_L=8 \quad P_o=1W$		120		kHz

URL: <http://www.szsanjing.com>

----- **TEL: 0755-29663136**

FAX: 0755-29663137 -----



TEST CIRCUIT

1.STEREO TEST CIRCUIT

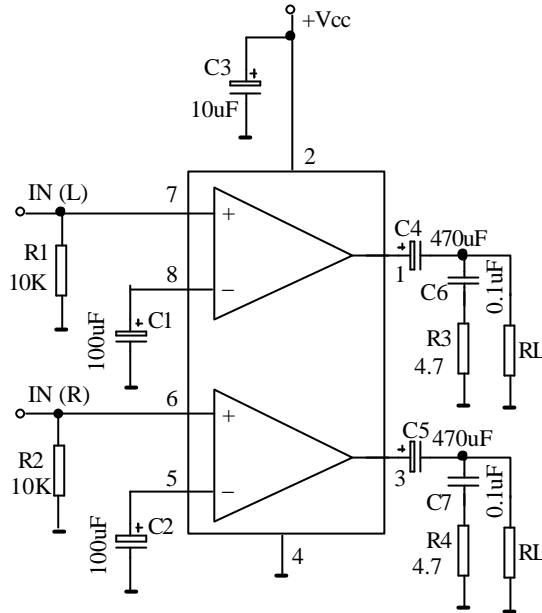

2.BRIDGE TEST CIRCUIT

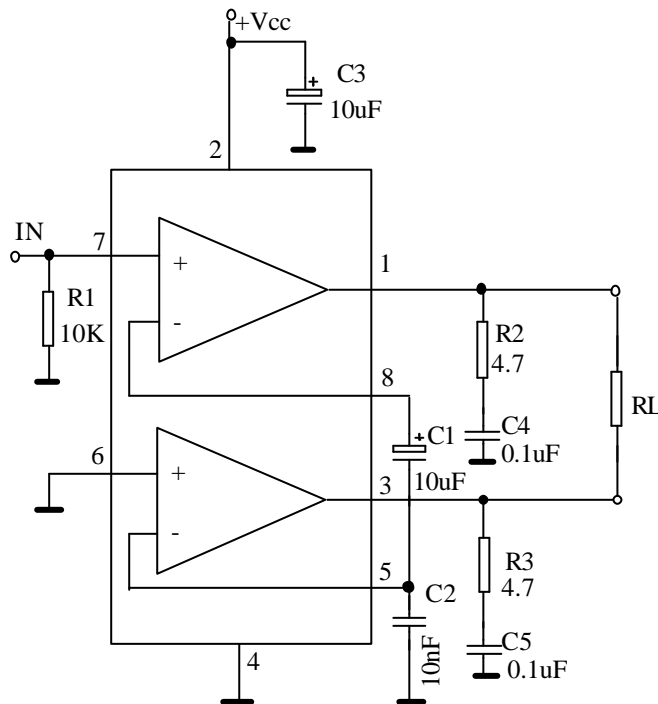

URL: <http://www.szsanjing.com>

----- TEL: 0755-29663136

FAX: 0755-29663137 -----



APPLICATION CIRCUIT

1. Typical application in portable players

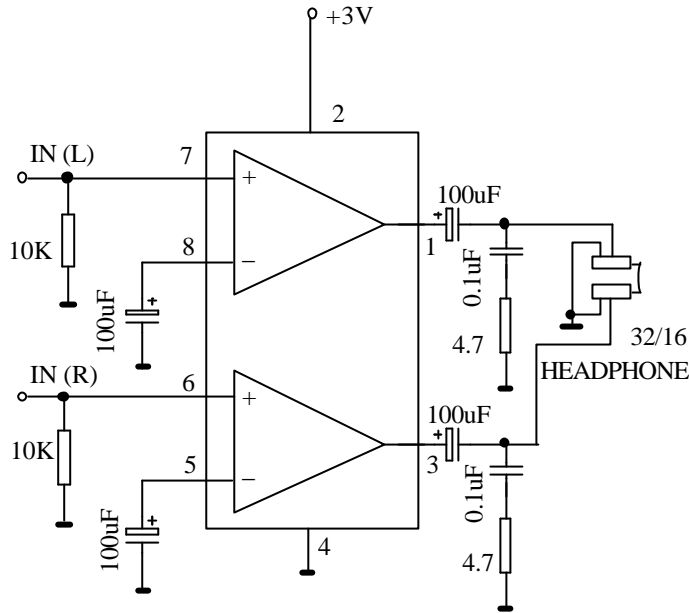

CHARACTERISTICS CURVES

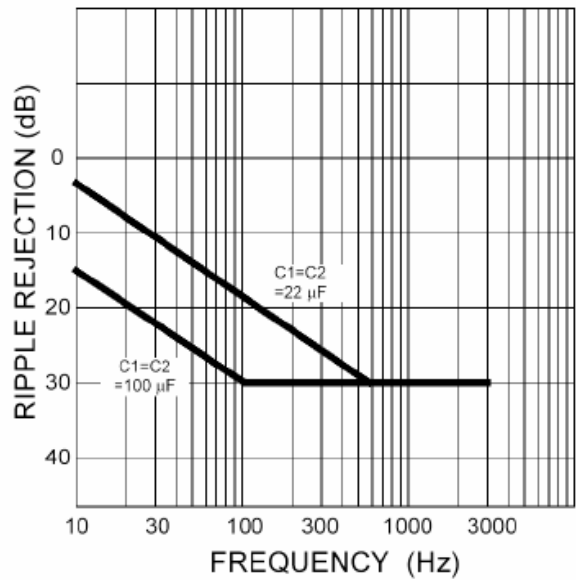
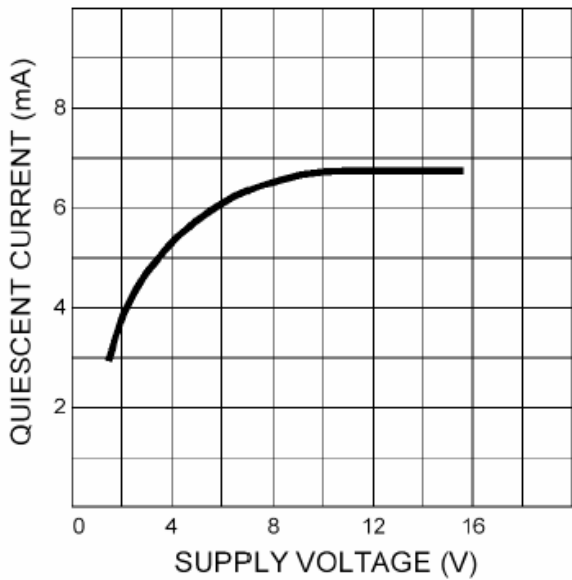

URL: <http://www.szsanjing.com>

----- TEL: 0755-29663136

FAX: 0755-29663137 -----



OUTLINE DRAWING :

1、(DIP)

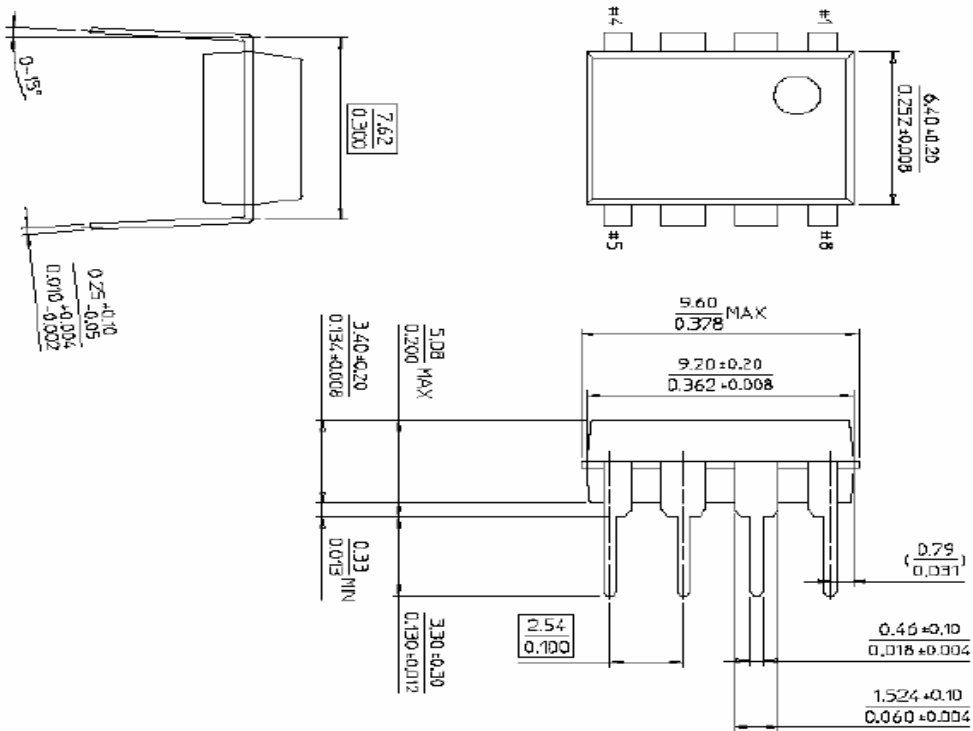

2、(SOP)

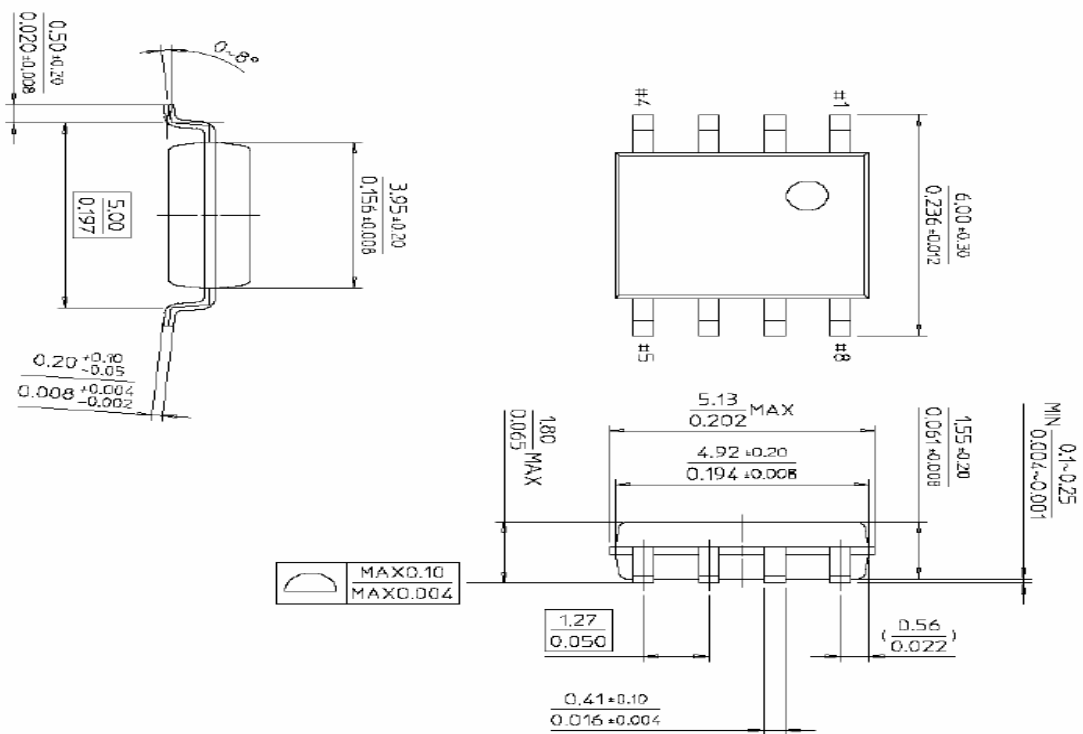

URL: <http://www.szsanjing.com>

TEL: 0755-29663136

FAX: 0755-29663137